

4. Set Bottom back support (#10) and top back support (#11) on a flat surface with curved side up. A table top pushed against a wall works great. Push the edge of supports against the wall while assembling to keep it square.

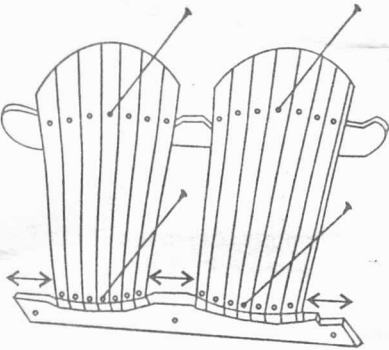

5. Put the two groups of seven back slats (#12) on the supports with the longest in the centres. Push the slats together until you have even spaces on both sides, then screw down the centre slats using 2 screws.

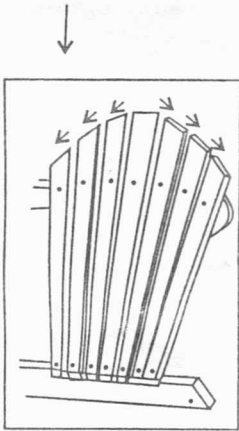

6. Space the slats out evenly from attached centre slats so that the outside is even with the ends of the curved back supports, then screw down all slats.

7. Attach the back assembly to the seat assembly with 3 screws.

